



Over 90 Years Of Quality Foodservice  
Products And Service

# Waffle Bakers

MODELS  WB-1E - Single Baker  WB-2E - Double Baker



Models WB-1E & WB-2E

## DESCRIPTION

Wells new improved single & double grid Standard Waffle Bakers provide versatility, are easy-to-use and bake the perfect waffle time after time. Operator adjustable, programmable, solid-state temperature and timer controls with digital display provide precise temperatures and perfect bake times for any waffle mix recipe.

## SPECIFICATIONS

**Construction** - Front, top, sides and drip tray are fabricated with heavy duty stainless steel for durability, ease-of cleaning and long life. Nickel-plated, open-coil handles minimize heat transfer for user safety.

**Controls & Heating** – Operator-controlled, programmable digital timers and temperature-controls allow the operators to precisely establish the perfect bake times and temperatures for his unique waffle batter. The timers are adjustable from 1 second to 10 minutes while temperatures are adjustable from 250°F - 425°F (121°C - 218°C). A manual, digital temperature display icon indicates the exact current temperature of the baking grids for temperature-ready start times while an audible electric alarm beeps when the baking cycle is complete. Lighted ON / Off rocker switches allows independent operation of each baking unit.

**Baking Grids & Hinges** – 7” diameter (178mm) energy efficient cast aluminum grids provide faster bake times and use less energy than hard-to-clean cast iron grids. Durable floating grid hinges allows the upper grid to rise evenly as the waffle expands during the baking cycle.

## STANDARD FEATURES

- Single or double waffle baker models
- 120V, 208/240V or 230V with cords & plugs
- Operator controlled programmable digital timer and temperature controls
- Digital time & temperature display
- Current temperature display icon
- Lighted ON/OFF indicator lights with rocker switches
- Audible end of bake cycle alarm
- Stainless steel top, front, sides and drip trays
- Nickel-plated open coil handles reduce heat transfer
- 7” (178 mm) diameter energy efficient cast aluminum grids
- Durable floating grid hinge

## OPTIONS & ACCESSORIES

- Replacement drip tray (WB-2E uses two)
- Replacement grids

## PRODUCT WARRANTY

- One year parts and year labor warranty

## CERTIFICATIONS



(800) 343-6890 [srscooks.com](http://srscooks.com)

SEATTLE  
RESTAURANT  
S ♦ T ♦ O ♦ R ♦ E



**Wells Bloomfield** • 10 Sunnen Dr. St. Louis, MO 63143 U.S.A.  
Phone : (314) 678-6314 • Fax (314) 781-5445  
[www.wellsbloomfield.com](http://www.wellsbloomfield.com) • Printed in the U.S.A.

**NOTE: Specifications are subject to change without notice and are not intended for installation purposes. See installation instructions prior to installing the unit.**



Over 90 Years Of Quality Foodservice  
Products And Service

# Waffle Bakers

MODELS □ WB-1E - Single Baker □ WB-2E - Double Baker

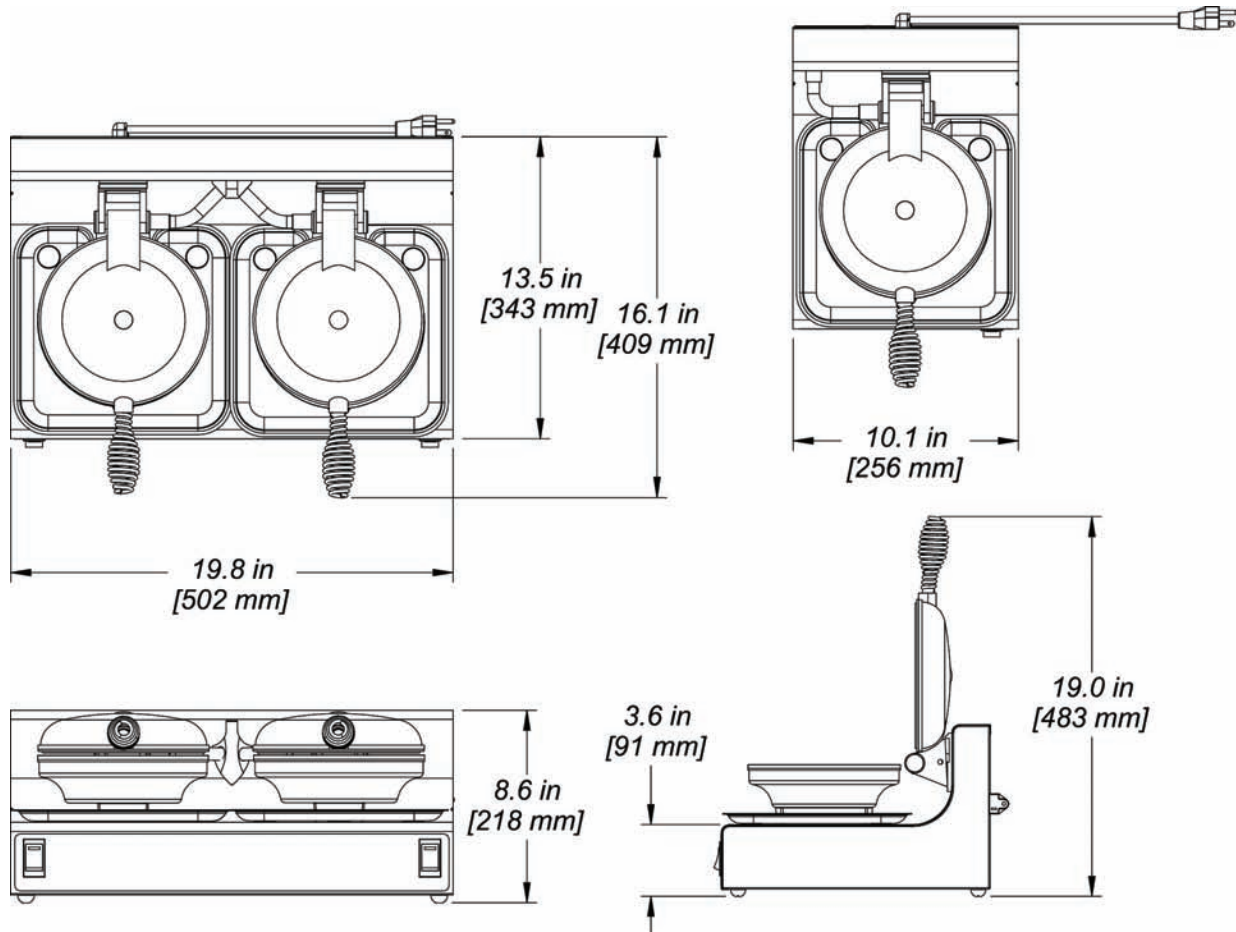

| Model No. | Description         | Height Closed (MM) | Width (MM)    | Depth (MM)<br>(not including handles) | Voltage | Watts     | AMPS    | NEMA           | Approx. Weight Shipping lbs. (kg) | Approx. Weight Installed lbs. (kg) |
|-----------|---------------------|--------------------|---------------|---------------------------------------|---------|-----------|---------|----------------|-----------------------------------|------------------------------------|
| WB-1E     | Single Waffle Baker | 8.6<br>(218)       | 10.1<br>(256) | 13.5<br>(343)                         | 120     | 900       | 7.5     | 5-15P          | 16<br>(7.3)                       | 15<br>(6.8)                        |
|           |                     |                    |               |                                       | 208/240 | 676/900   | 3.3/3.8 | 6-15P          |                                   |                                    |
|           |                     |                    |               |                                       | 220/240 | 900       | 3.8     | CE VII 436U    |                                   |                                    |
| WB-2E     | Double Waffle Baker | 8.6<br>(218)       | 19.8<br>(502) | 13.5<br>(343)                         | 120     | 1800      | 15.0    | 5-20P          | 30<br>(13.6)                      | 28<br>(12.7)                       |
|           |                     |                    |               |                                       | 208/240 | 1352/1800 | 6.5/7.5 | 6-15P          |                                   |                                    |
|           |                     |                    |               |                                       | 220/240 | 1800      | 7.5     | CEE 7/VII 436U |                                   |                                    |

Due to periodic changes in designs, methods, procedures, policies and regulations, the specifications contained in this sheet are subject to change without notice. While Wells exercises good faith efforts to provide information that is accurate, we are not responsible for errors or omissions in information provided or conclusions reached as a result of using the specifications. By using the information provided, the user assumes all risks in connection with such use.



**Wells Bloomfield** • 10 Sunnen Dr. St. Louis, MO 63143 U.S.A.  
Phone : (314) 678-6314 • Fax (314) 781-5445  
www.wellsbloomfield.com • Printed in the U.S.A.

**NOTE: Specifications are subject to change without notice and are not intended for installation purposes. See installation instructions prior to installing the unit.**