



(800) 343-6890 srscooks.com

SEATTLE
RESTAURANT
S•T•O•R•E

SRCO & SRCO-2

CONVECTION OVENS

The Sierra SRCO features an all-stainless steel construction, that includes three stainless steel inshot burners with a total output of 54,000 BTU/hr, providing lightning-quick heating. The stainless front, top and sides, galvanized back panel, and porcelain enamel interior allows for easy cleaning. Five nickel plated oven racks with eleven position interior rack guides allow for an easy modular customization.

The SRCO features a modern look and design, form and function fit for the most demanding kitchens at an affordable price.

The SRCO Single Oven comes with the SRCO-LK leg kit, including 4 black enamel legs with locking casters (4)

The SRCO-2 Double Stacked Ovens come with the SRCO-SK stacking kit, including heavy duty casters (locking in front), separator tray, exhaust flue extension and mounting hardware.



STANDARD FEATURES

- Three inshot burners - 18,000 BTU each with a 54,000 total BTU output
- Independent doors with two windows
- 2-speed, 1/2 hp fan motor (1725, 1140 rpm)
- Porcelain enamel oven interior
- Five nickel plated oven racks with eleven position interior rack guides
- Electronic ignition (Fenwall)
- Electronic thermostat & manual timer controls (FAST)
- Temperature range: 150°F to 500°F (66°C to 260°C)
- Control panel opens downward for easy service, located on right side away from burners
- Two Halogen interior lights
- Exterior: stainless front, top and sides, galvanized back panel
- Oven Ready light
- Forced "cool down" fan mode
- Set of four black painted carbon steel legs
- Anchor point on oven back for restraining cable
- The SRCO is shipped from the factory, ready for natural gas installation. An LP conversion kit is included with each unit.

TECHNICAL DRAWINGS

SPECIFICATIONS

MODEL NUMBER	SRCO	SRCO-2
EXTERNAL DIMENSIONS (WxDxH)	38.12" X 44.37" X 60"	38.12" X 44.37" X 65.62"
INTERNAL DIMENSIONS (WxDxH)	29" X 22.5" X 19.75"	29" X 22.5" X 19.75"
RACK CLEARANCE	28" WIDTH, 21" DEPTH	28" WIDTH, 21" DEPTH
NUMBER OF BURNERS	3	3 + 3
TOTAL BTU	54,000	108,000
NET WEIGHT	450 LBS	817 LBS
SHIPPING WEIGHT	617 LBS	1234 LBS

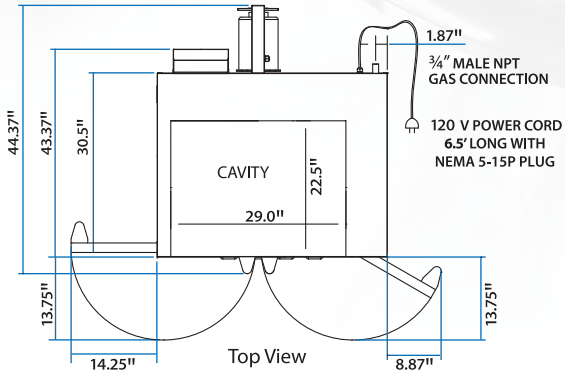

Single Oven with Leg and Caster Kit

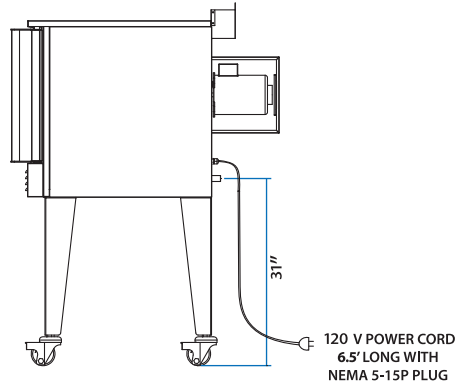
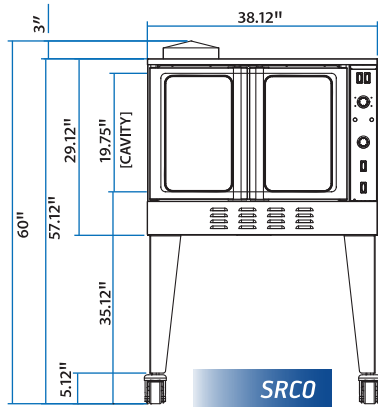

Dual Oven Configuration with Stacking Kit

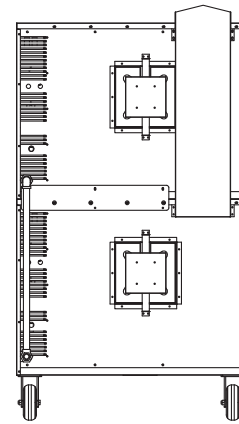
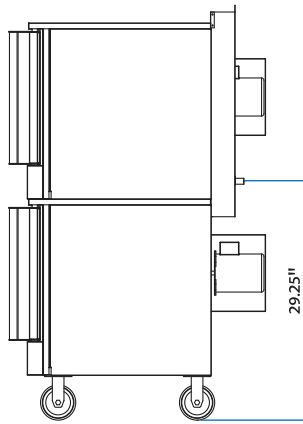
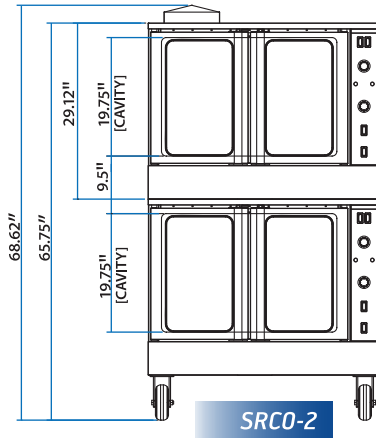

Warranty: 12 months parts & labor.

Gas Connection: 3/4" NPT on the right hand rear of the appliance. The pressure regulator (supplied) is to be connected here by the installer.

Electrical Requirement: 120 Volts AC, 7.9 amps per oven

Gas pressure: 4" W.C. - Natural Gas | 10" W.C. - Propane

Combustible Clearances: For use in non-combustible locations | Non-combustible Clearances: 0 inches sides, 0 inches rear

Specify type of gas and altitude, if over 2,000 feet, when ordering.

A restraining kit is required for ovens installed with a caster kit. Check your local code.

SIERRA RANGE is a registered trademark of **MVP Group**.

Due to continuing product development, to ensure best possible performance, the specifications are subject to change without prior notice.